



Tutorial: Triggering & Synchronizing Multiple Chronos Cameras

Multiple Chronos cameras can be easily triggered simultaneously and synced, regardless of their model.

This tutorial will outline three different ways to trigger multiple Chronos cameras:

1. Trigger multiple cameras using a trigger switch cable
2. Trigger and synchronize multiple cameras simultaneously using a Transmitter/Receiver camera
3. Synchronize shutters on multiple cameras using an external signal source

Trigger Multiple Cameras using Trigger Switch Cable

This setup allows users to trigger multiple Chronos cameras to start and end recording from an external switch, but will not output synchronized footage. Different resolutions, frame rates, and/or record times can be set for each camera, since footage synchronization is not critical for this setup.

Trigger and Synchronize Multiple Cameras Simultaneously using Transmitter/Receiver Camera

This setup allows users to trigger and synchronize multiple Chronos cameras simultaneously. This method allows users to trigger multiple cameras to start and stop (similar to [Trigger Multiple Cameras using Trigger Switch Cable](#) section), but it also includes another trigger to synchronize the frames on all the cameras. This method is recommended for Digital Image Correlation (DIC), 3D reconstruction, and Particle Image Velocimetry (PIV) applications. **Note: there can only be one transmitter camera, but multiple receiver cameras.**

Synchronize Shutters on Multiple Cameras using External Signal Source

This setup allows users to exactly synchronize the frames on multiple cameras using an external signal source. The signal source can be a signal generator, microcontroller, Data Acquisition System (DAQ), or Programmable Logic Controller (PLC). This method will allow users to synchronize multiple camera shutters using the shutter gating feature. The setup described in this section requires the user to manually set cameras to start/end recording using the touchscreen or using the camera web interface.

Table of Contents

1. Trigger Multiple Cameras using Trigger Switch Cable	3
1.1 Parts Needed:	3
1.2 How to Set Up:	3
1.3 Trigger/IO Settings:	5
1.3.1 Trigger I/O Settings for Stop Recording via Record End Trigger	5
1.3.2 Trigger I/O Settings for Start and Stop Recording via Toggle Trigger	7
1.3.3 Trigger Delays	7
2. Trigger and Synchronize Multiple Cameras Simultaneously using Transmitter/Receiver Camera	8
2.1 Parts Needed:	8
2.2 How to Set Up:	9
2.2.1 Transmitter Camera	9
2.2.2 Receiver Camera	10
2.3 Trigger/IO Settings:	11
2.3.1 Record End Trigger	11
2.3.1.a Transmitter Camera Settings	11
2.3.1.b Receiver Camera Settings	12
2.3.2 Toggle Trigger	12
2.3.2.a Transmitter Camera Settings	12
2.3.2.b Receiver Camera Settings	13
3. Synchronize Shutters on Multiple Cameras using External Signal Source	14
3.1 Parts Needed:	14
3.2 How to Set Up:	14
3.3 Trigger/IO Settings:	16
3.3.1 I/O1 Port:	16
3.3.2 I/O2 Port:	17
Additional Notes	18

1. Trigger Multiple Cameras using Trigger Switch Cable

This setup allows users to trigger multiple Chronos cameras to start and end recording from an external switch, but will not output synchronized footage. Different resolutions, frame rates, and/or record times can be configured for each camera, since footage synchronization is not critical for this setup.

1.1 Parts Needed:

Item/Component	Reference/Vendor
1x Trigger Switch Cable	https://www.krontech.ca/store/Trigger-Switch-cable-p89703348
1x BNC Tee	https://www.krontech.ca/store/BNC-Tee-p89703353
1x BNC male to male cable (long enough to connect between transmitter and receiver camera)	https://www.krontech.ca/store/30m-100-BNC-extension-cable-p89703356

* The parts list is for triggering 2X Chronos cameras. If you are triggering more than two cameras, add an additional BNC Tee and BNC cable for each additional camera.

1.2 How to Set Up:

- Connect the trigger switch cable to the BNC Tee and connect the BNC Tee to the transmitter camera.

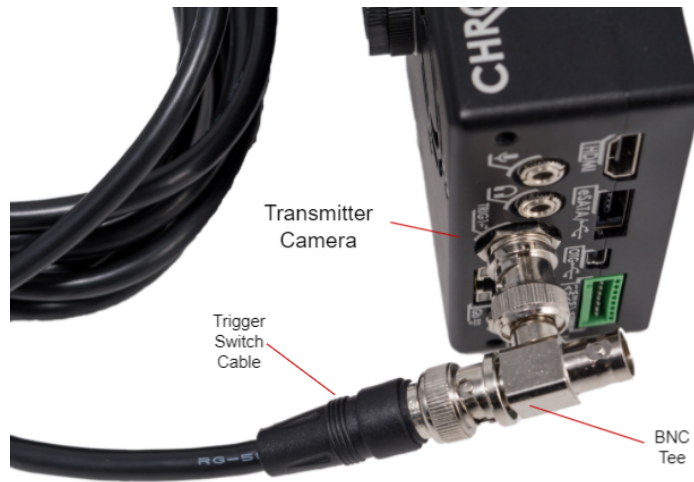

- Connect the receiver BNC extension cable to the BNC Tee on the transmitter camera.

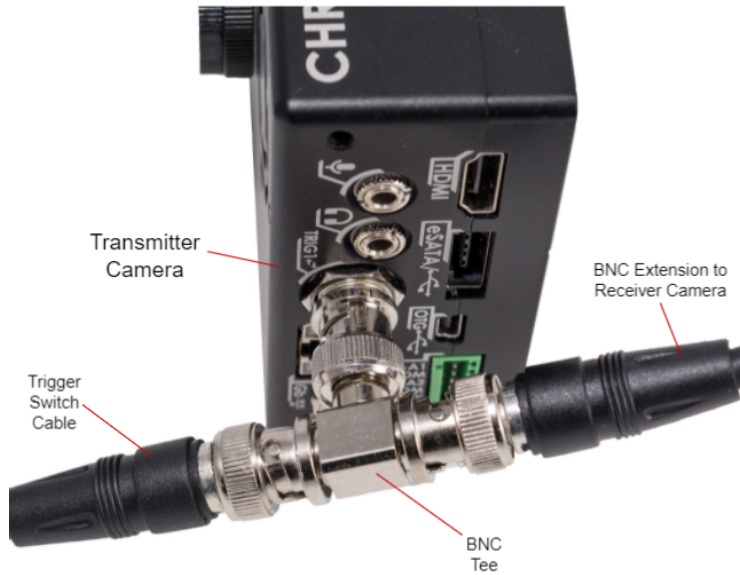

- Connect the other end of the BNC extension cable to the I/O1 BNC connector of the receiver camera.



1.3 Trigger/I/O Settings:

The Chronos cameras provide two triggering options with a trigger switch cable: Record End Trigger and Toggle trigger.

[Record End trigger](#) is used when the cameras are set to record in a continuous buffer and are expected to end recording instantaneously with a press of a button.

[Toggle trigger](#) is used to start and stop recording with a press of a button, but the user does not mind a 10-30ms delay when starting a recording.

To get started, enter the “TRIGGER I/O Settings” menu on your Chronos camera.

1.3.1 Trigger I/O Settings for Stop Recording via Record End Trigger

This configuration allows users to use a single trigger button press to end recording on multiple cameras simultaneously. Note that you would still have to start each camera recording manually.

- In the TRIGGER/I/O 1 window, set up the transmitter camera's trigger settings as follows:
 - Record End Trigger
 - Invert

- 20mA Pullup
- Debounce
- Press “Apply” and “OK”

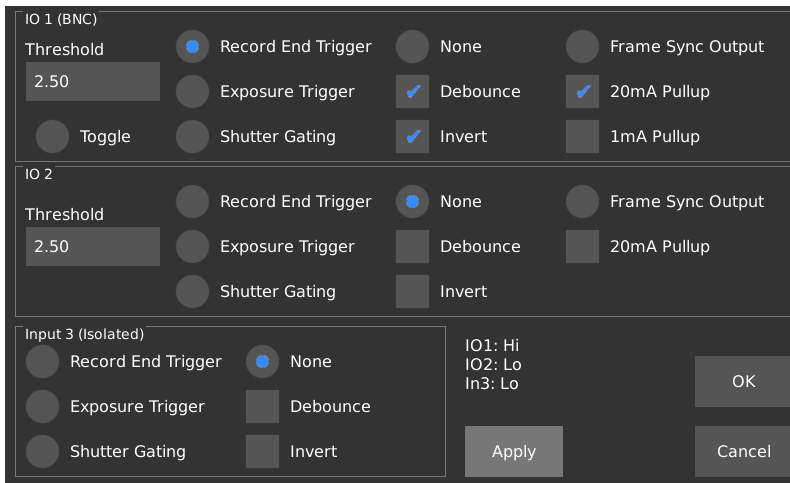

- In the TRIGGER/IO 1 window, set up the receiver camera's trigger settings as follows:
 - Record End Trigger
 - Invert
 - Debounce
 - Press “Apply” and “OK”

Note: use the following settings on any additional receiver cameras included in your setup.

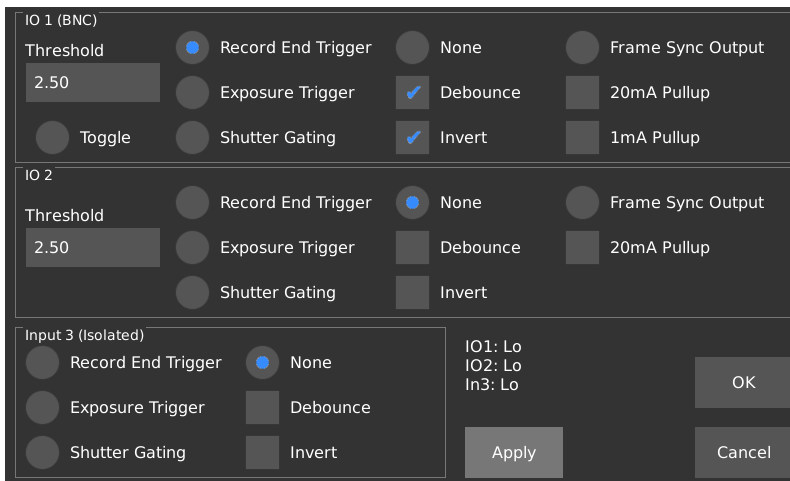

1.3.2 Trigger I/O Settings for Start and Stop Recording via Toggle Trigger

This configuration allows users to start or stop a recording on every connected camera by pressing a single trigger button.

Warning: when using the toggle trigger setting, starting a new recording will always overwrite any existing footage in the camera's memory buffer. Accidentally starting a new recording will result in loss of footage. To avoid the risk of losing footage, users could enable the “Auto Save” feature in the Util > Main page. The Auto Save feature will automatically save the recorded footage with preset save settings to the selected storage location.

- In the TRIGGER/IO 1 window, set up both camera's trigger settings as follows:
 - Toggle
 - 20mA Pullup
 - Press “Apply” and “OK”

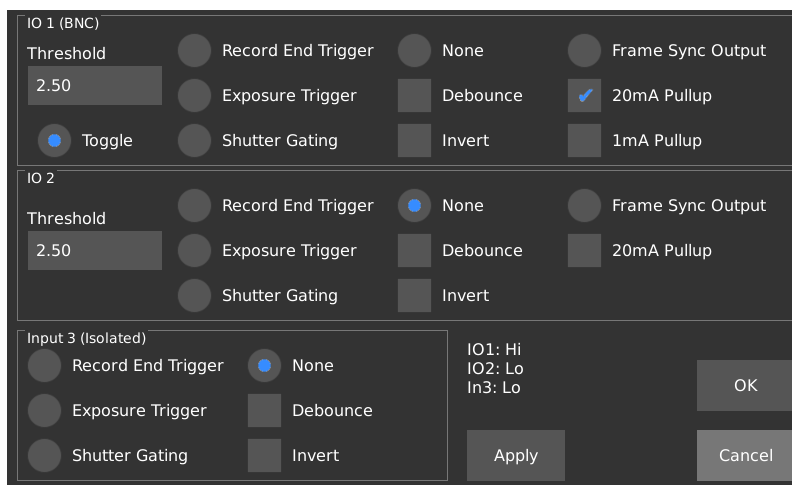

1.3.3 Trigger Delays

- Confirm Post-trigger Delay settings (Record Settings > Trigger Delay) are set at the same values. To prevent any delays, press “Reset to Defaults” and “Ok” on both cameras to set post-trigger values to 0.

In case your camera does not respond to stop recording, then confirm post-trigger values in the “Trigger Delay” page are set to 0.

2. Trigger and Synchronize Multiple Cameras Simultaneously using Transmitter/Receiver Camera

This setup allows users to trigger and synchronize multiple Chronos cameras simultaneously. This method allows users to trigger multiple cameras to start and stop (similar to [Trigger Multiple Cameras using Trigger Switch Cable](#) section), but it also includes another trigger to synchronize the frames on all the cameras. The camera model, resolutions and record lengths can vary on each camera, but the frame rates (fps) set on the receiver cameras have to be equal to or greater than the transmitter camera. However, the transmitter camera's frame rate will define the receiver's frame rate.

For instance, a Chronos 2.1 camera (transmitter) set to 1920 x 1080p @ 1000 fps with 11 seconds record length can be synchronized with a Chronos 1.4 (receiver) 1280x 1024 @ 1069 fps with 8 seconds record length. The recorded footage on each camera will be 1000fps. Since the record lengths differ, the recorded footage can be synchronized from the end of the recording by using the last frame from each footage as a reference

This method is recommended for Digital Image Correlation (DIC), 3D reconstruction, and Particle Image Velocimetry (PIV) applications. **Note: there can only be one transmitter camera, but multiple receiver cameras.**

2.1 Parts Needed:

Item/Component	Reference/Vendor
1x Trigger Switch Cable	https://www.krontech.ca/store/Trigger-Switch-cable-p89703348
1x BNC Tee	https://www.krontech.ca/store/BNC-Tee-p89703353
1x BNC male to male cable (long enough to connect between transmitter and receiver camera)	https://www.krontech.ca/store/30m-100-BNC-extension-cable-p89703356
Hook up wire (22 to 24 AWG) (long enough to connect between transmitter and receiver camera)	

<p>2x Green terminal blocks for Chronos 1.4-1.0 cameras.</p>	<p>Phoenix Contact part number 1881383, available here</p>
<p>OR</p>	<p>OR</p>
<p>2x Black terminal blocks for Chronos 1.4-1.1 and Chronos 2.1-1.0 cameras</p>	<p>Phoenix Contact part number 1778890, available here</p>
<p>Note: Chronos model info is found at the bottom of the cameras.</p>	

* The parts list is for triggering 2X Chronos cameras. If you are triggering more than two cameras, allow for additional parts for the additional cameras.

2.2 How to Set Up:

2.2.1 Transmitter Camera

- Connect the trigger switch cable to the BNC Tee and connect the BNC Tee to the I/O1 BNC port of the transmitter camera.
- Connect an I/O1 BNC extension cable to the other end of the BNC Tee.
- Connect the Green or Black Phoenix connector to the Trig2 and Trig3 port.
- Using the 22 Awg or 24 Awg hookup wires, connect one wire to the TRG2 and another to any of the 3 COM ports.

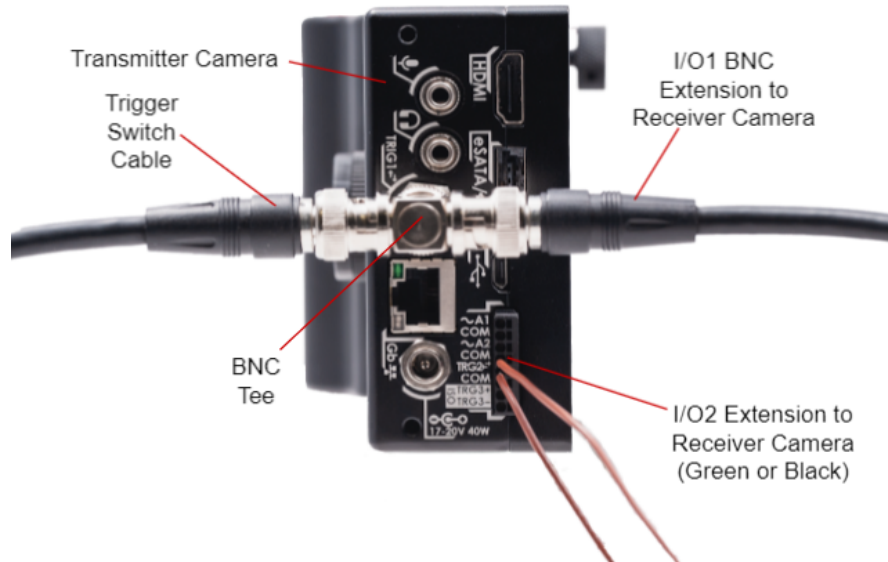

2.2.2 Receiver Camera

- Connect the other end of the BNC extension cable to the I/O1 BNC connector of the receiver camera.
- Connect the Green or Black Phoenix connector to the Trig2 and Trig3 port.
- Using the 22 Awg or 24 Awg hookup wires, connect the two TRG2 connections together, and the two COM connections together. You can connect the wires to any of the 3 COM ports.

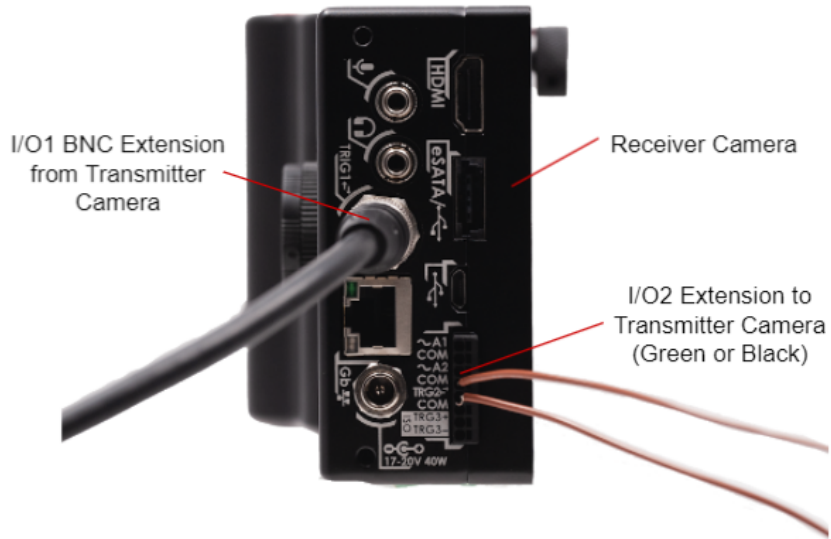

- The final camera setup should appear to be similar to the diagram shown below.

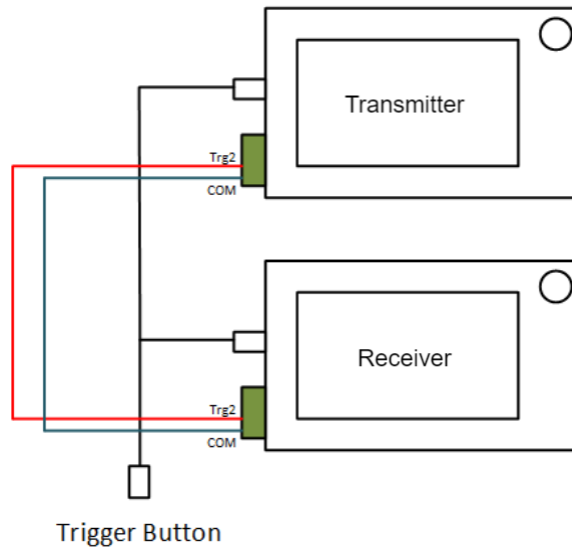

2.3 Trigger/IO Settings:

There are two options for synchronizing the cameras:

- Follow [2.3.1 Record End Trigger](#) to end the recording with a button press.
- Follow [2.3.2 Toggle Trigger](#) to start and stop recording. Note: 10-30ms delay is expected when starting a recording.

2.3.1 Record End Trigger

This configuration allows users to synchronize frames on multiple cameras, and end all of the camera's recordings with a button press. Note that you would still have to start each camera recording manually.

2.3.1.a Transmitter Camera Settings

- In the Trigger settings window, set up the transmitter camera's trigger settings as follows:
 - I/O1:
 - Record End Trigger
 - Invert
 - Debounce
 - 20mA Pullup
 - I/O2:
 - Frame Sync Output
 - 20mA Pullup
 - Press "Apply" and "OK"

The screenshot shows a settings window with three sections: IO 1 (BNC), IO 2, and Input 3 (Isolated). IO 1 is configured with Record End Trigger, Invert, Debounce, and 20mA Pullup. IO 2 is configured with Frame Sync Output and 20mA Pullup. Input 3 is configured with None. The window also includes an IO summary box and Apply/Cancel buttons.

IO	Threshold	Record End Trigger	None	Frame Sync Output	Exposure Trigger	Debounce	20mA Pullup	Toggle	Shutter Gating	Invert	1mA Pullup
IO 1 (BNC)	2.50	<input checked="" type="radio"/>	<input type="radio"/>	<input type="radio"/>	<input type="radio"/>	<input checked="" type="checkbox"/>	<input checked="" type="checkbox"/>	<input type="checkbox"/>	<input type="checkbox"/>	<input checked="" type="checkbox"/>	<input type="checkbox"/>
IO 2	2.50	<input type="radio"/>	<input type="radio"/>	<input checked="" type="radio"/>	<input type="radio"/>	<input type="checkbox"/>	<input checked="" type="checkbox"/>	<input type="checkbox"/>	<input type="checkbox"/>	<input type="checkbox"/>	<input type="checkbox"/>
Input 3 (Isolated)		<input type="radio"/>	<input checked="" type="radio"/>		<input type="radio"/>	<input type="checkbox"/>		<input type="checkbox"/>	<input type="checkbox"/>	<input type="checkbox"/>	

IO Summary: IO1: Hi, IO2: Hi, In3: Lo

Buttons: Apply, Cancel, OK

2.3.1.b Receiver Camera Settings

- In the Trigger settings window, set up the receiver camera's trigger settings as follows:
 - I/O1:
 - Record End Trigger
 - Invert
 - Debounce
 - I/O2:
 - Shutter Gating
 - Press “Apply” and “OK”

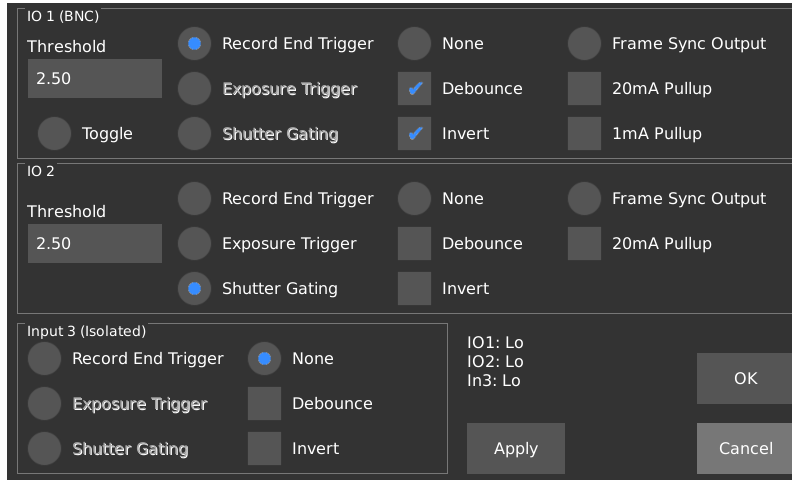

2.3.2 Toggle Trigger

This configuration allows users to synchronize frames and start or stop a recording on every connected camera by pressing a single trigger button.

Warning: when using the toggle trigger setting, starting a new recording will always overwrite any existing footage in the camera's memory buffer. Accidentally starting a new recording will result in loss of footage. To avoid the risk of losing footage, users could enable the “Auto Save” feature in the Util > Main page. The Auto Save feature will automatically save the recorded footage with preset save settings to the selected storage location.

2.3.2.a Transmitter Camera Settings

- In the Trigger settings window, set up the transmitter camera's trigger settings as follows:
 - I/O1:
 - Toggle
 - 20mA Pullup

- I/O2:
 - Frame Sync Output
 - 20mA Pullup
- Press “Apply” and “OK”

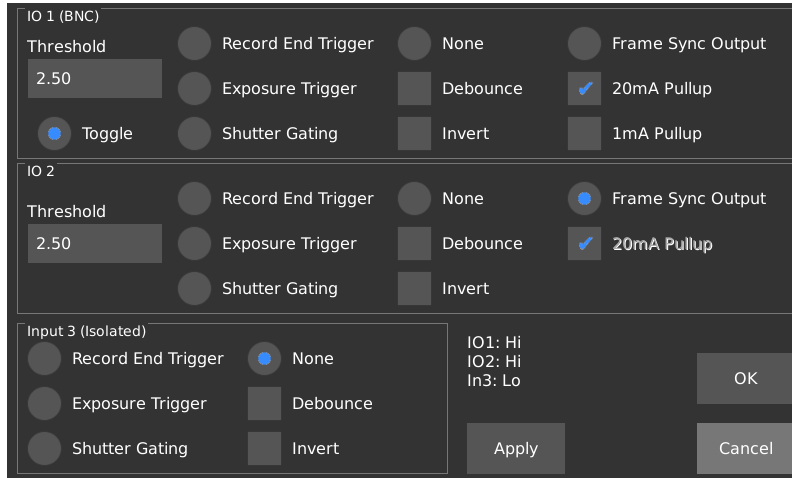

2.3.2.b Receiver Camera Settings

- In the Trigger settings window, set up the receiver camera's trigger settings as follows:
 - I/O1:
 - Toggle
 - 20mA Pullup
 - I/O2:
 - Shutter Gating
 - Press “Apply” and “OK”

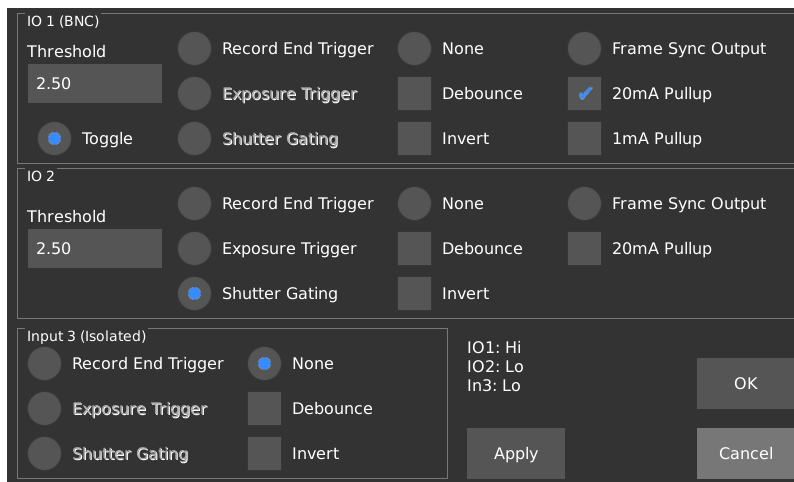

3. Synchronize Shutters on Multiple Cameras using External Signal Source

This setup allows users to exactly synchronize the frames on multiple cameras using an external signal source. The signal source can be a signal generator, microcontroller, Data Acquisition System (DAQ), or Programmable Logic Controller (PLC). This method will allow users to synchronize multiple camera shutters using the shutter gating feature. A secondary trigger port can be added to the setup (similar to [Trigger Multiple Cameras using Trigger Switch Cable](#) section) to trigger the camera to start/end recording. The setup described in this section requires the user to manually set cameras to start/end recording using the touchscreen or using the camera web interface.

Users can set the resolution, frame rate, and record lengths on each camera. The signal source will define the actual frame rate and exposure time of each camera. However, the maximum achievable frame rate set by signal source has to be equal to or less than the framerate set by each camera. Like in previous sections, both Chronos 1.4/2.1 cameras can be used in a setup simultaneously.

3.1 Parts Needed:

Item/Component	Reference/Vendor
1x Signal/ Function Generator	
1x BNC Tee	https://www.krontech.ca/store/BNC-Tee-p89703353
2 x BNC male to male cable (long enough to connect between transmitter and receiver camera)	https://www.krontech.ca/store/30m-100-BNC-extension-cable-p89703356

* The parts list is for triggering 2X Chronos cameras. If you are triggering more than two cameras, allow for additional parts for the additional cameras.

3.2 How to Set Up:

- Connect a BNC Tee to Signal Generator port and connect a BNC extension cable on each end.

- Setup a repetitive trigger signal to control the camera shutters. An example setting is provided below:
 - Waveform: Square Wave Signal.
 - Frequency: 800 Hz. It means the camera will capture 800fps. The frequency values must be lower than the set frame rate in record settings.
 - Amplitude: 5V. As a rule of thumb, this value should be 2 times the I/O Threshold.
 - Offset: 2.5V.
 - Duty Cycle: 50%. Defines the exposure time.

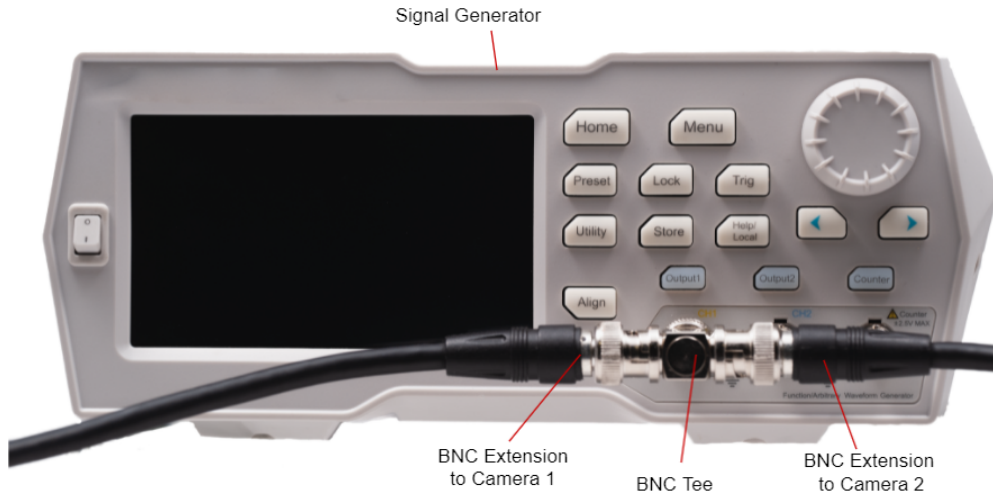

- Connect a BNC Extension Cable to the I/O BNC port of each camera. This type of connection is more common with signal generators.

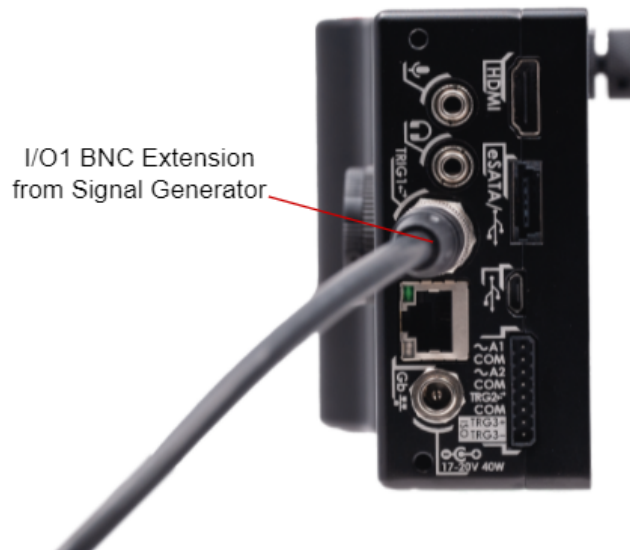

- OR connect two wires (Trig2 and COM) from a signal source to a phoenix connector and mount on the side of the camera. This type of connection is more common with microcontrollers, PLCs, and DAQs.

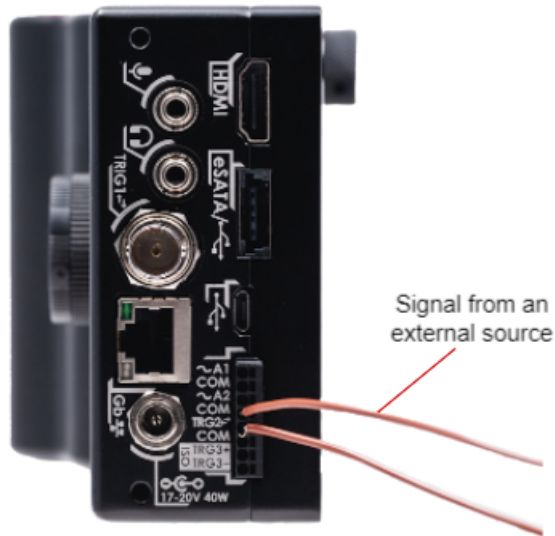

3.3 Trigger/IO Settings:

With this setup, both cameras have to be manually set to start/end recording. The camera shutter will be controlled by pulses generated by the signal source.

3.3.1 I/O1 Port:

- In the Trigger settings window, set up the receiver camera's trigger settings as follows:
 - I/O1:
 - Shutter Gating
 - Press "Apply" and "OK"

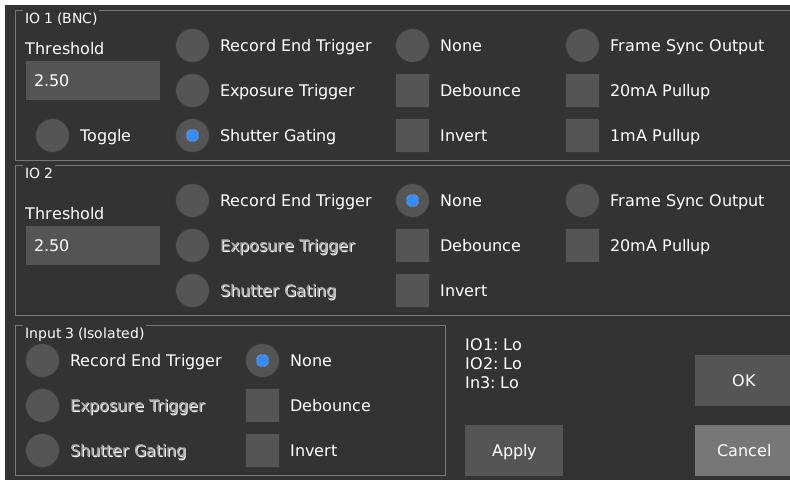

3.3.2 I/O2 Port:

- In the Trigger settings window, set up the receiver camera's trigger settings as follows:
 - I/O2:
 - Shutter Gating
 - Press “Apply” and “OK”

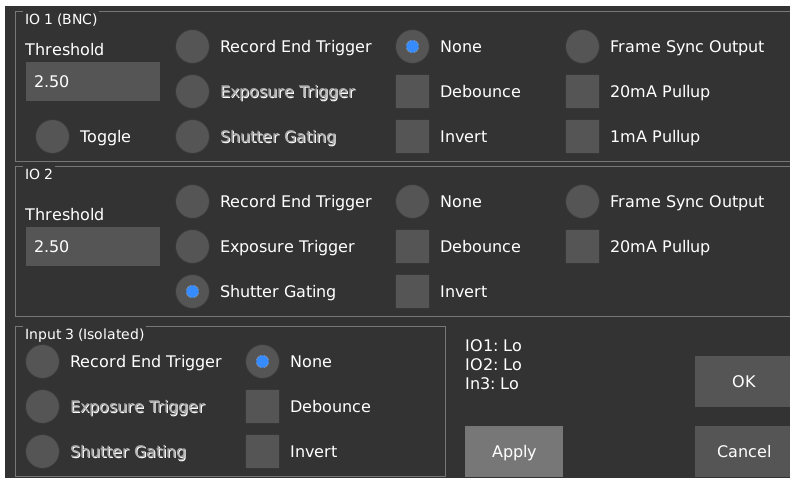

Additional Notes

These are some notes that might be useful to user's setup:

- Enable timestamps using "Text Overlay (H.264/TIFF)" in the save settings of each Chronos camera. Timestamps will help facilitate cross referencing synchronized frames. This feature can only be displayed for H.264 and TIFF files.
 - Set saving format to H.264, if interested in saving a video footage.
 - Set saving format to TIFF, if interested in saving individual footage files.
 - Set saving format to cinemaDNG, if interested in saving raw footage files.
However, a time stamp is not available for this format.
- Save footage using SMB and NFS network shares to avoid transferring footage files from multiple SD cards, SSDs, and USBs.
- Enable "Auto Save" in the Util menu to save footage immediately after ending recording.
- Chronos 1.4 and 2.1 cameras can be synchronized if the frame rates are set to the same value or the receiver cameras have a greater frame rate than the transmitter camera. The camera resolution and record lengths will not directly impact the synchronization. Note: the transmitter camera's frame rate will define the receiver's frame rate.
- Change "Record length" value in the Record Settings > Record Mode, to reduce maximum footage time.
- Confirm Post-trigger values in the Record Settings > Trigger Delay values are set to zero to prevent any delays when stopping a recording. In case the triggers do not work as expected, confirm trigger delays are correctly configured.

Checklist:

1. Setup Camera trigger Connections
2. Configure camera record settings : Resolution, gains, frame rates
3. Configure Trigger Settings
4. Configure Record length in Record Settings > Record Mode (optional)
5. Configure Post-Trigger in Record Settings > Trigger Delay ("Reset to Default" and press "OK" for no delays)
6. Perform [Black Calibration](#) based on the instructions in the user manual
7. Start recording!

For more Chronos 1.4 and 2.1 resources, visit our website: <https://www.krontech.ca/>

Please contact us through support@krontech.ca if you need any more information or require further assistance.

Date: (2021-06-22)